

## HCM1012G SERIES (Chip Common Mode Filter) Engineering Specification



### Features and Application

- Powerful components with composite co-fired material to solve EMI problem for high speed differential signal transmission line as USB, and LVDS, without distortion to high speed signal transmission.
- MIPI, MHL serial interface in mobile device.

### 1.PRODUCT DETAIL

Part No.	Imp. Com. (Ω)±25% @100MHz	DCR Max. (Ω)	Rated Current Max.(mA)	Rated Voltage (V)	Insulation Resistance Min.(MΩ)	Withstand Voltage (V)
HCM1012GH360AP	36	0.7	100	10	100	25
HCM1012GH900BP	90	2.0	100	10	100	25
Test Instruments	<ul style="list-style-type: none"> <li>•Agilent E4991A RF IMPEDANCE / MATERIAL ANALYZER</li> <li>•HP4338 MILLIOHMMETER</li> <li>•Agilent E5071C ENA SERIES NETWORK ANALYZER</li> <li>•Keithley 2410 1100V SOURCE METER</li> </ul>					

### 2.PART NUMBER CODE

HCM 1012 G □ 90 0 □ P  
 1      2      3      4      5      6      7      8

- 1 : Series name
- 2 : Dimensions L\*W
- 3 : Material code
- 4 : Product identification number
- 5 : Impedance value (ex : 900=90Ω)
- 6 : Fixed decimal point
- 7 : INPAQ internal code
- 8 : Packaging style  
P – Embossed paper tape, 7”reel.

3.TYPICAL CHARACTERISTIC

**HCM1012GH360**

IMPEDANCE vs. FREQUENCY CHARACTERISTICS

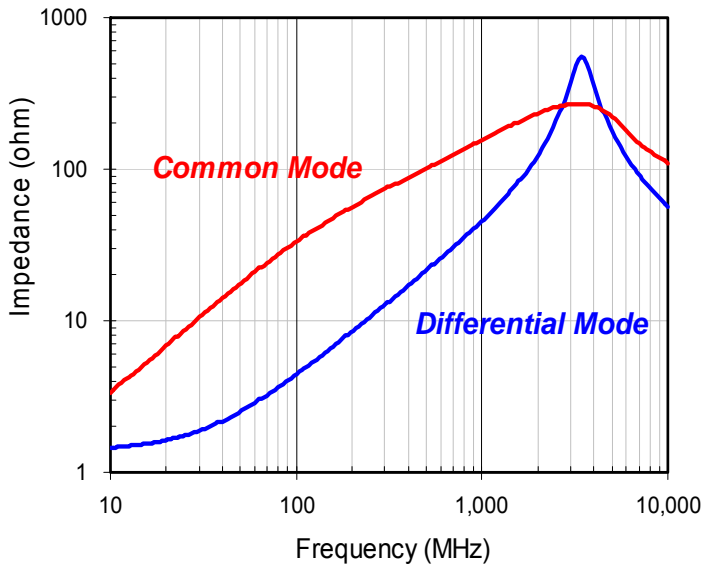

INSERTION LOSS vs. FREQUENCY CHARACTERISTICS

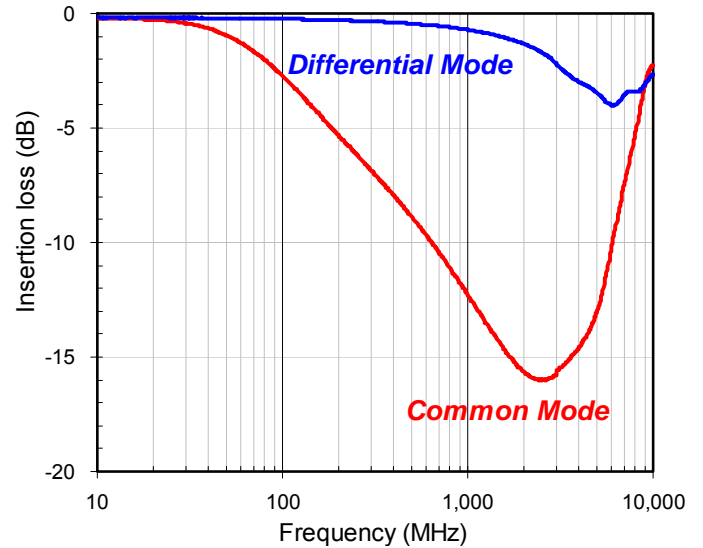

**HCM1012GH900**

IMPEDANCE vs. FREQUENCY CHARACTERISTICS

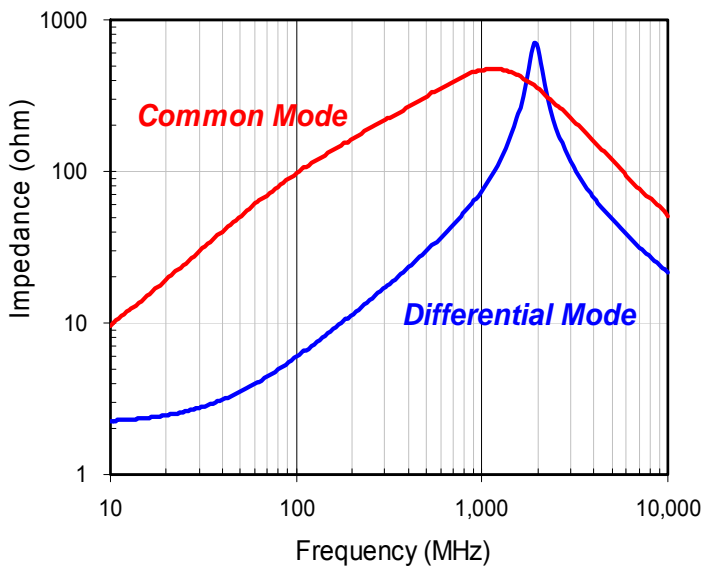

INSERTION LOSS vs. FREQUENCY CHARACTERISTICS

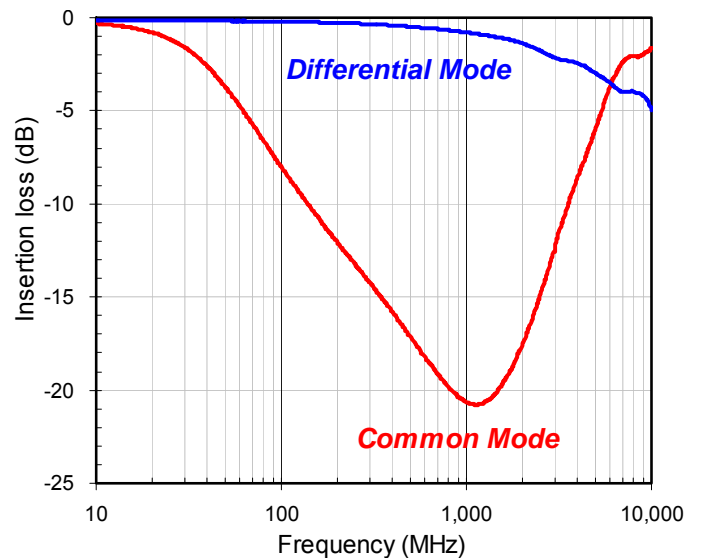

4. SHAPES AND DIMENSIONS

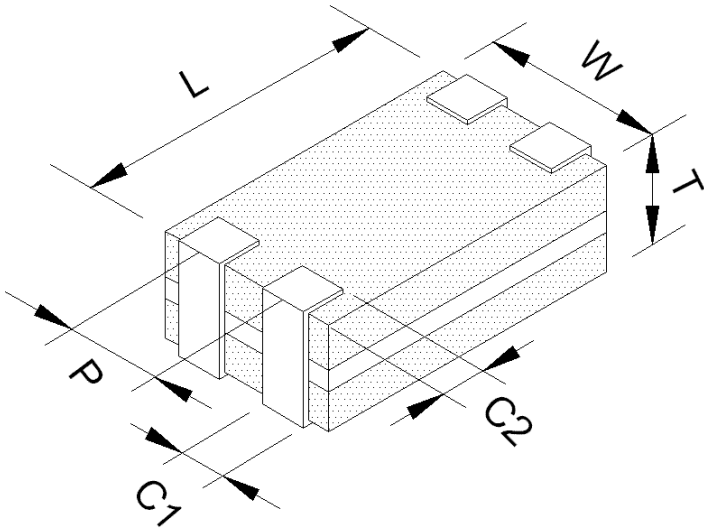

TYPE	Dimension
L	1.25±0.10
W	1.00±0.10
T	0.60±0.10
P	0.50±0.10
C1	0.30±0.10
C2	0.20±0.15
Unit : mm	

5. CIRCUIT CONFIGURATION & LAYOUT PAD

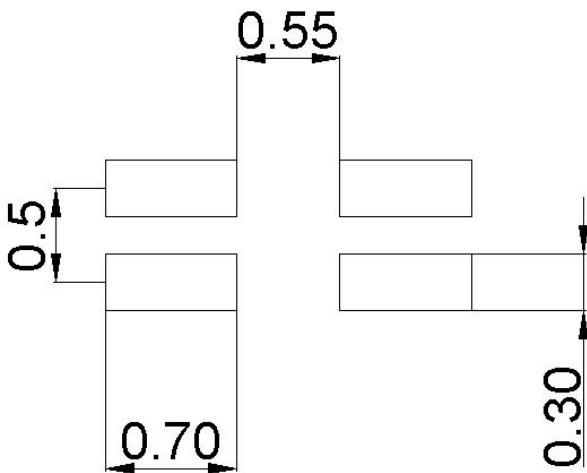
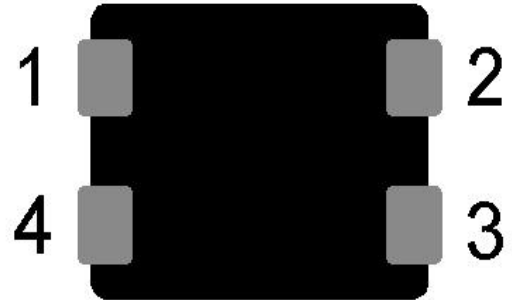
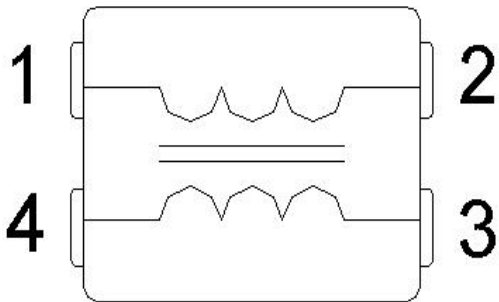

6.TAPE AND REEL SPECIFICATIONS/ TAPING DIMENSIONS

Type : Paper Carrier

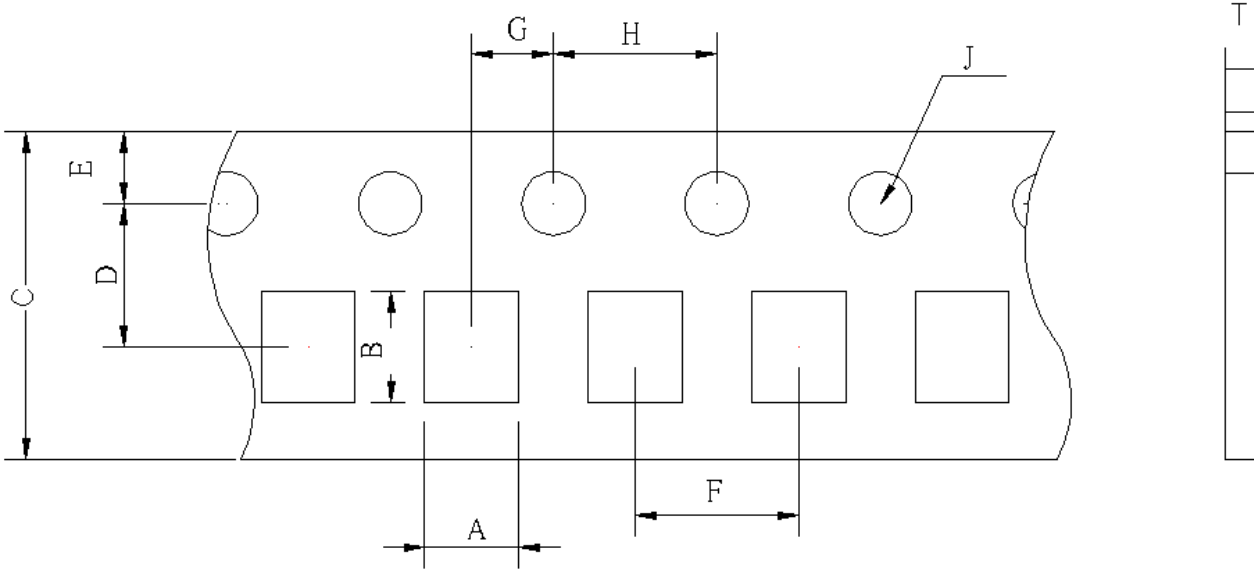

Unit : mm

Symbol	Size	Symbol	Size
C	8.00±0.10	H	4.00±0.10
D	3.50±0.05	J	Φ1.55±0.05
E	1.75±0.05	T	0.75±0.03
F	4.00±0.10	A	1.20±0.05
G	2.00±0.05	B	1.45±0.05

7. REEL DIMENSIONS

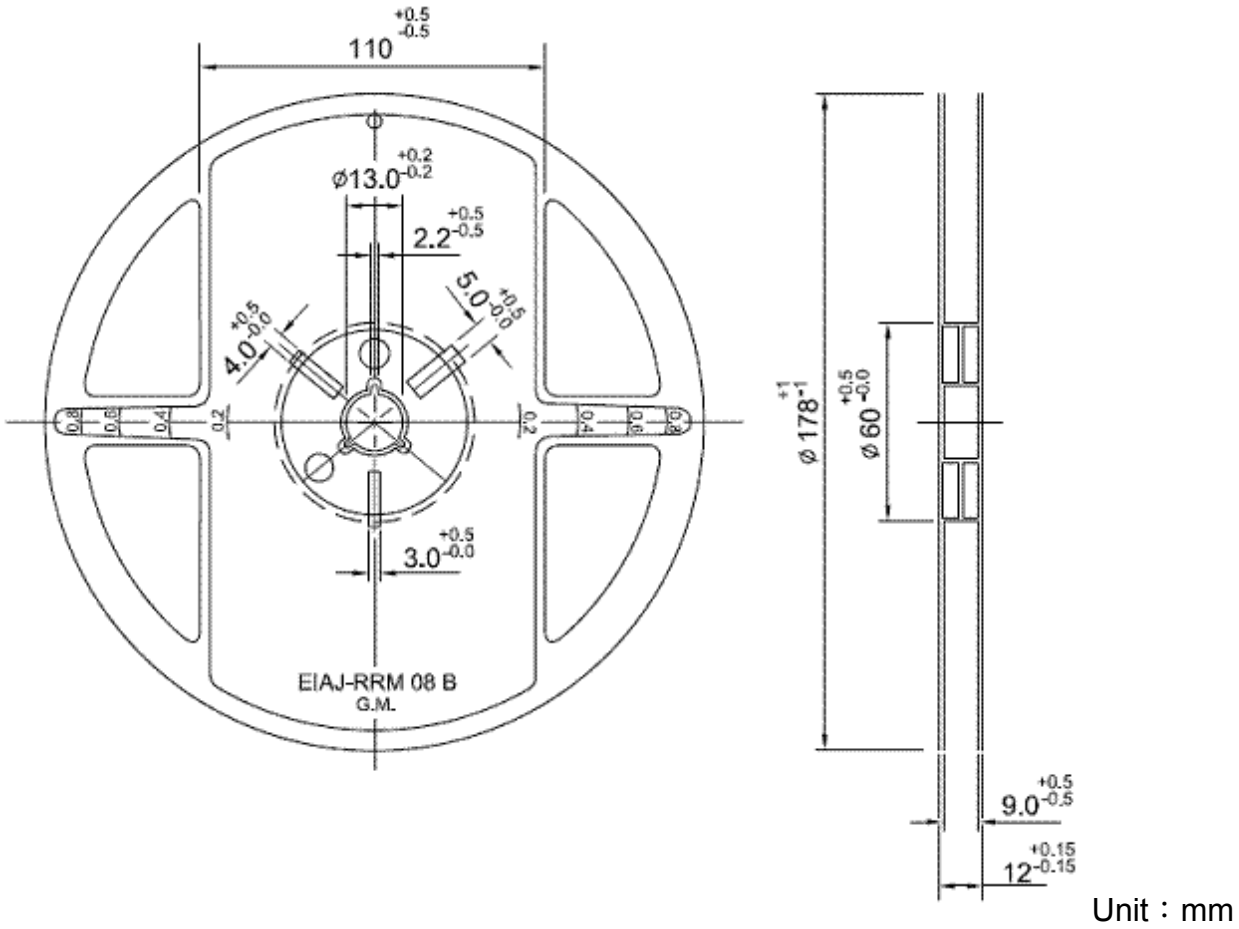

8. STANDARD QUANTITY FOR PACKAGING

Packaging style : Taping

Reel packaging quantity : 4000 pcs/reel

Inner box : 5 reel/inner box

9.RECOMMENDED SOLDERING CONDITIONS

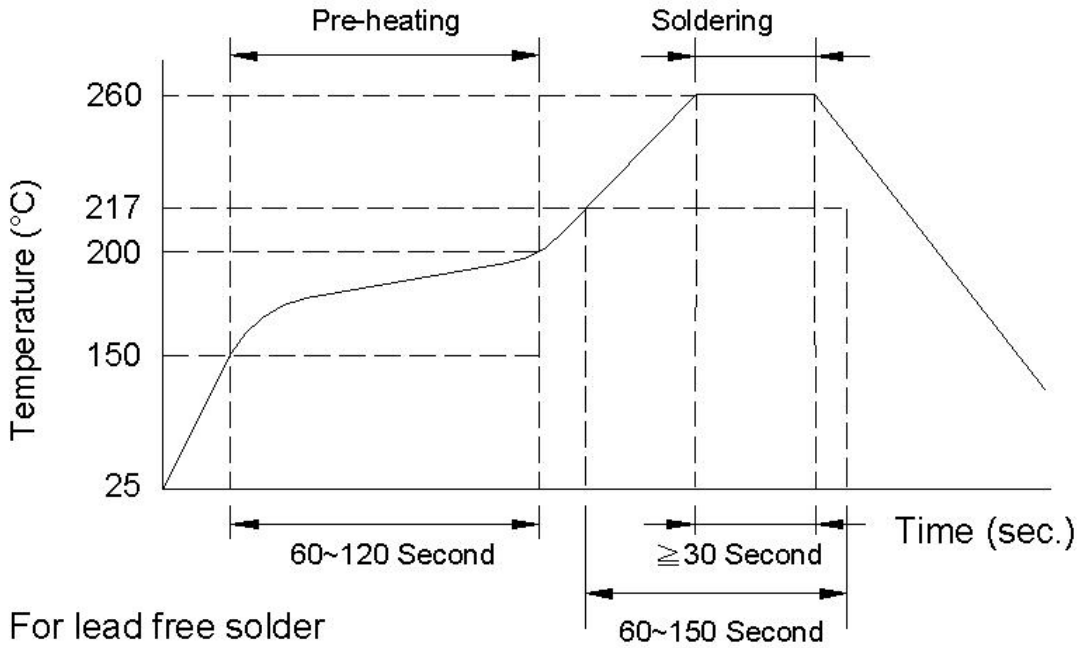

10.GENERAL TECHNICAL DATA

- Operating temperature range : - 40°C ~ +85°C
- Storage Condition : Less than 40°C and 70% RH
- Storage Time: 6 months Max.
- Soldering method: Reflow or Wave Soldering

## 11.RELIABILITY AND TEST CONDITION

Test item	Test condition	Criteria
<b>Temperature Cycle</b>	A. Temperature : -40 ~ +85°C B. Cycle : 100 cycles C. Dwell time : 30minutes Measurement : at ambient temperature 24 hrs after test completion	A. No mechanical damage B. Impedance value should be within $\pm 20\%$ of the initial value
<b>Operational Life</b>	A. Temperature : 85°C $\pm$ 5°C B. Test time : 1000 hrs C. Apply current : full rated current Measurement : at ambient temperature 24 hrs after test completion	A. No mechanical damage B. Impedance value should be within $\pm 20\%$ of the initial value
<b>Biased Humidity</b>	A. Temperature : 40 $\pm$ 2°C B. Humidity : 90 ~ 95 % RH C. Test time : 1000 hrs D. Apply current : full rated current Measurement : at ambient temperature 24 hrs after test completion	A. No mechanical damage B. Impedance value should be within $\pm 20\%$ of the initial value
<b>Resistance to Solder Heat</b>	A. Solder temperature : 260 $\pm$ 5°C B. Flux : Rosin C. DIP time : 10 $\pm$ 1 sec	A. More than 95 % of terminal electrode should be covered with new solder B. No mechanical damage C. Impedance value should be within $\pm 20\%$ of the initial value
<b>Steam Aging Test</b>	A. Temperature : 93 $\pm$ 2°C B. Test time : 4 hrs C. Solder temperature : 235 $\pm$ 5°C D. Flux : Rosin E. DIP time : 5 $\pm$ 1 sec	More than 95 % of terminal electrode should be covered with new solder